

# VINYLTECH AWWA C900-07

## TECHNICAL DATA SUBMITTAL



### CONFORMANCE

These specifications designate the requirements for manufacturing and installing Vinyltech AWWA C900-07 water pipe.

**AWWA C900-07** - Polyvinyl Chloride (PVC) Pressure Pipe and Fabricated Fittings, 4 In. Through 12 In. (100mm Through 300mm), for Water Transmission and Distribution

**AWWA C605** - Underground Installation of Polyvinyl Chloride (PVC) Pressure Pipe and Fittings for Water

**ASTM D1784** - Standard Specification for Rigid Poly (Vinyl Chloride) (PVC) Compounds and Chlorinated Poly (Vinyl Chloride) (CPVC) Compounds

**ASTM D3139** - Standard Specification for Joints for Plastic Pressure Pipes Using Flexible Elastomeric Seals

**ASTM F477** - Standard Specification for Elastomeric Seals (Gaskets) for Joining Plastic Pipe

**ASTM D2412** - Standard Test Method for Determination of External Loading Characteristics of Plastic Pipe by Parallel-Plate Loading

### PIPE COMPOUND

The pipe shall be extruded from compounds meeting (PVC1120) the requirements of Cell Classification 12454, as defined in ASTM D1784, Standard Specification for Rigid Poly (Vinyl Chloride) (PVC) Compounds and Chlorinated Poly (Vinyl Chloride) (CPVC) Compounds. The PVC shall also be listed by the National Sanitation Foundation (NSF) for use in potable water.

### PIPE

Vinyltech pipe shall be manufactured in accordance with AWWA C900-07.

### GASKET JOINT

The gasket shall be reinforced with a steel band and meet the requirements of ASTM F477. Vinyltech pipe shall have an integral bell end with a locked-in factory installed gasket and shall meet the joint requirements of ASTM D3139.

### MARKING

The pipe shall be marked in accordance with AWWA C900 as in the following example.

- Manufacturer's name and production codes
- Nominal size, dimension ratio number, and O.D. base (for example, 8" DR 18 CIS)
- Materials cell classification (PVC1120)
- AWWA pressure class (235 psi or 305 psi) and hydrostatic test pressure (T600, or T800)
- AWWA designation number (AWWA C900-07)
- National Sanitation Foundation (NSF-61)
- Underwriters Laboratories (UL) logo, third party certification.
- Production date and time code (VABB15B 48.34)
- FM Approvals (FM) logo, required FM pressure rating (150 or 200 psi), third party certification

### QUALITY CONTROL

Each length of the pipe including the bell shall be hydrostatically tested. The pipe shall meet all additional test requirements as described in AWWA C900-07. Our full-time quality assurance staff continually administers a rigid program of tests to maintain the production of the best pipe products available.

### INSTALLATION

Recommended installation procedures of Vinyltech Corporation are outlined in AWWA C605, Underground Installation of Polyvinyl Chloride (PVC) Pressure Pipe and Fittings for Water. The AWWA Manual M23, PVC Pipe-Design and Installation, is also an invaluable resource guide for design and installation.

### TAPPING

The consistent success of tapping PVC pressure pipe is contingent upon the use of proper procedures and equipment. Vinyltech recommends strict compliance with the requirements as specified in AWWA C605.

### ASSEMBLING THE PIPE

Assembly of Vinyltech PVC water pipe is easily accomplished. A depth of entry mark is on each spigot end to serve as a visual check for rapid, accurate joint inspection. **Do not over insert.**

- Remove any mud, sand, or other foreign matter from the belled and spigot ends of the pipe. Carefully clean the gasket area.
- With a clean applicator (a brush or hand) lubricate the entire surface of the pipe from the spigot end to the depth of entry mark and the contact surface of the gasket with **Vinyltech Brand Lubricant**.
- Brace the bell to avoid disturbing the already installed joints. Align the pipe, insert the spigot into the bell and push.
- Do not insert past the entry mark line.**



201 S. 61st Avenue • Phoenix, AZ 85043  
602 233-0071 • 602 272-4847 Fax • www.vtpipe.com



AWWA C900-07

# VINYLTECH AWWA C900-07

## TECHNICAL DATA SUBMITTAL

### C900 DR 18 PRESSURE CLASS 235

NOMINAL SIZE (IN) (mm)	OUTER DIAMETER (IN)	MINIMUM WALL (IN)	LIFTS PER TRUCK	FEET PER LIFT	APPROXIMATE WEIGHT (LB/100')
4 (100)	4.800	0.267	16	1020	251.6
6 (150)	6.900	0.383	16	440	521.2
8 (200)	9.050	0.503	20	200	903.0
10 (250)	11.100	0.617	12	240	1364.4
12 (300)	13.200	0.733	28	60-80	1935.8

### C900 DR 14 PRESSURE CLASS 305

NOMINAL SIZE (IN) (mm)	OUTER DIAMETER (IN)	MINIMUM WALL (IN)	LIFTS PER TRUCK	FEET PER LIFT	APPROXIMATE WEIGHT (LB/100')
4 (100)	4.800	0.343	16	1020	317.5
6 (150)	6.900	0.493	16	440	658.7
8 (200)	9.050	0.646	20	200	1139.7
10 (250)	11.100	0.793	12	240	1722.3
12 (300)	13.200	0.943	28	60-80	2445.5

### CROSS SECTIONAL VIEW

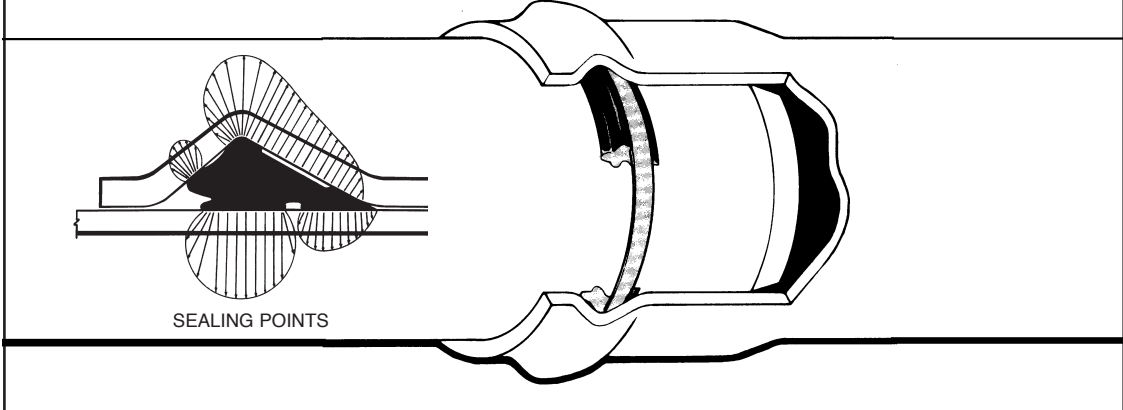

## THE RIEBER SEALING SYSTEM

The Rieber system provides a proven pipe joint with an excellent track record in the field. It is the fastest growing system in the world because of its many advantages.

- Factory installed, locked-in gasket
- The pipe bell forms over the gasket, making a perfect fit
- Avoids the possibility of installing the wrong gasket
- Reduces installation problems
- The locked-in gasket eliminates gasket roll-out during joining
- The gasket is molded vs. extruded and spliced
- Works equally well under pressure or vacuum
- Three sealing points achieved vs. two
- **LEAK-PROOF JOINTS**
- **“THE WORLDS BEST JOINT”**

**AWWA C900-07**